

# GS EVO GALV 25S4 1150X525

Galvanised hand pallet truck (2.500 kg)



## GS EVO GALV

The GS EVO GALV hand pallet truck is designed to handle loads in humid and damp conditions.

Suitable for environments where high hygienic standards are enforced, such as the chemical, pharmaceutical or food & beverage industry.

Very good resistance to corrosion, guaranteed thanks to the hot dip galvanizing process of the frame and the handle, and geomet treatment on the rest of components.

## HYDRAULIC UNIT

Resistant and reliable one piece cast iron pump with GEOMET® surface coating treatment to prevent rust pitting and corrosion damages. Designed with extreme care of details in order to have superior characteristics and features, it includes:

- **Monolithic design:** resistant and reliable one-piece housing to protect all components avoiding any accidental damages. Pump housing is processed with CNC machines to achieve high precision tolerances and high accuracy.
- **Chromed piston rod and oil seal:** in order to avoid rust and prevent oil leakage during the use.
- **Maximum pressure valve:** safety device that protects the transpallet against overloads.
- **PROPORTIONAL LOWERING VALVE:** lowering speed can be proportionally controlled according to the lever position on the tiller. Perfect working tool to carry fragile and delicate loads like crystal, glass and ceramics.



2500 kg



200 mm



## TILLER

3D Superior Ergonomic shape tiller, with enhanced ergonomics. Compared to a conventional tiller, this shape allows the operator to have a good position when pushing the loads with maximum efficiency without fatigue. This thanks to two large grasping side areas specifically designed to have a correct position during operation of the truck.



## EASY TO MOUNT

Tiller easy to assemble with a fast mounting system. Robust tiller connection with two full welded joints that assure superior sturdiness in the toughest application.

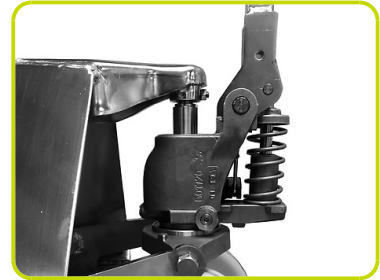

## Descrizione

1.1 Costruttore		LIFTER
1.3 Tipo di Propulsione		Manuale
1.4 Sistema di guida		Accompagnamento
1.5 Portata	Q Kg	2500
1.6 Baricentro	c mm	600
1.8 Distanza asse ruote di carico da base forca	x mm	932
1.9 Passo	y mm	1192

## Pesi

2.1 Massa in servizio	Kg	63
2.2 Carico asse posteriore (pieno carico)	Kg	1825
2.2 Carico asse anteriore (pieno carico)	Kg	738
2.3 Carico asse posteriore (senza carico)	Kg	21
2.3 Carico asse anteriore (senza carico)	Kg	42

## Telaio/Ruote

3.1 Gommatura, anteriore		NYLON
3.1 Gommatura posteriore		NYLON
3.2 Dimensione ruote anteriori - Diametro	mm	200
3.2 Dimensione ruote anteriori - Larghezza	mm	50
3.3 Dimensione ruote posteriori - Diametro	mm	82
3.3 Dimensione ruote posteriori - Larghezza	mm	60
3.5 Dimensioni ruote posteriori - Q.tà (x=motrice)	nr	4
3.5 Ruote basculanti		No
3.6 Carreggiata anteriore	b10 mm	155
3.7 Carreggiata posteriore	b11 mm	375

## Dimensioni

4.4 Altezza di sollevamento	h3 mm	115
4.9 Altezza del timone in posizione di guida max	h14 mm	1185
4.9 Altezza del timone in posizione di guida min	h14 mm	710
4.15 Altezza forche abbassate	h13 mm	85
4.19 Lunghezza totale	l1 mm	1550
4.20 Lunghezza unità motrice	l2 mm	400
4.21 Larghezza totale	b1 mm	525
4.22 Dimensioni forche - Spessore	s mm	55
4.22 Dimensioni forche - Larghezza	e mm	150
4.22 Lunghezza forche	l mm	1150
4.25 Larghezza forche	b5 mm	525
4.32 Luce libera a metà passo	m2 mm	30
4.34 Corridoio di stivaggio per pallet 800x1200 longitudinalmente	Ast mm	2048
4.35 Raggio di volta	Wa mm	1367

## Prestazioni

5.2 Velocità di sollevamento con carico	pompate	12
5.2 Velocità di sollevamento senza carico	pompate	12

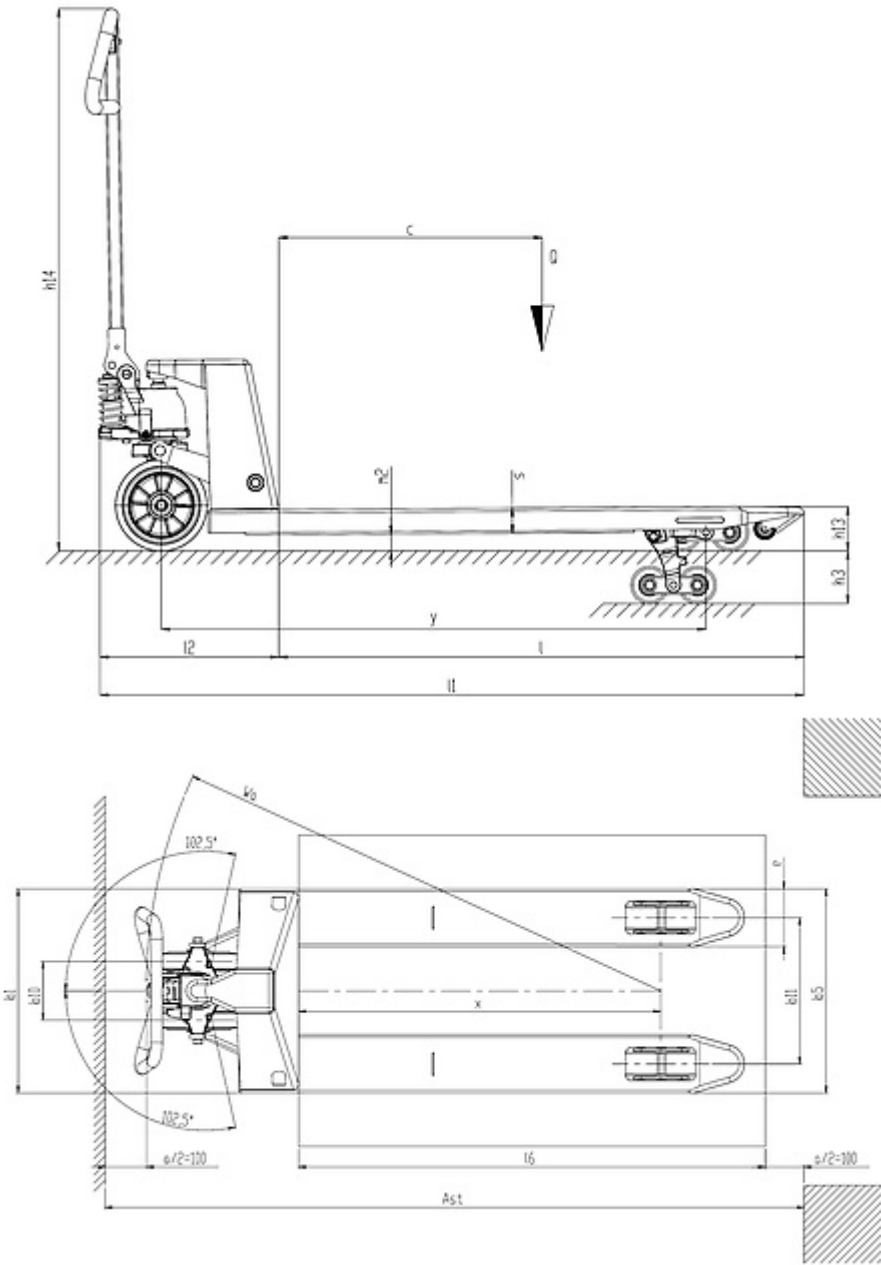

The information is aligned with the Data file at the time of download. Printed on 29/12/2020 (ID 12774)

©2020 | PR INDUSTRIAL s.r.l. | All rights reserved | Image shown may not reflect actual package. Specifications subject to change without notice

