

GS/P EVO 25S4 1185X555

THE INTELLIGENT SCALE PALLET TRUCK



SCALE TRUCK GS/P

The GS/P pallet truck is an intelligent and robust tool to be used for weighing and transporting your loads at the same time, making stock and dispatch processes faster, simpler and more efficient. The machine can be equipped with supplements such as printer or USB and thanks to the 4 load cells it is able to be very precise and functional; ideal for checking incoming goods, avoiding overloads and determining shipping weights.



DISPLAY

Its large-sized 6 digits LCD display provides accurate and precise weighing in kg and lb. Its software allows not only net/gross/tare weighing but also unit counting, adding and totalling of multiple loads. Weights are shown in 1 kg/lb steps with 0,05% precision.



FRAME STRUCTURE

The structure is designed with a double frame consisting of a lower fork on which stands a counter fork. Both forks house two load cells allowing a uniform load distribution, and keeping high weighing accuracy even in case of collision and unbalanced load.



BATTERY and BATTERY CHARGER

The GS/P is supplied complete with rechargeable battery and charger. The battery module provides 50 hours autonomy.



CONFIGURATION

STANDARD:

Nylon polyurethane steering wheels and polyurethane rollers

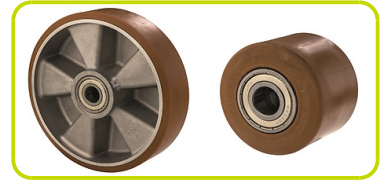

OPTIONAL:

Rubber steering wheels



PRINTER / USB (Supplement, only available at time of order)

As supplement, the machine can be equipped with a built-in printer, able to print gross, tare and net weights (kg or lb), date, quantity of pieces on the scale.

It may also be enriched with another supplement, the USB, allowing you to store weighing data in a text file, for archiving and processing via PC.



Description

1.1 Manufacturer			LIFTER
1.3 Drive			Manual
Lift			Manual
1.4 Operator type			Pedestrian
1.5 Load capacity	Q	Kg	2500
1.6 Load centre distance	c	mm	600
1.8 Load axle to end forks	x	mm	975
1.9 Wheel base	y	mm	1250

Weights

2.1 Service weight (battery included)		Kg	117
2.2 Axle load, laden rear		Kg	1836
2.2 Axle load, laden front		Kg	781
2.3 Axle load, unladen front		Kg	71
2.3 Axle load, unladen rear		Kg	46

Tyres/Chassis

3.1 Tyres: front wheels			POLY.I./ NYLON
3.1 Tyres: rear wheels			POLY.I.
3.2 Tyre size: Steering wheels - Width		mm	55
3.2 Tyre size: Steering wheels - Diameter		mm	200
3.3 Tyre size: Load rollers - Diameter		mm	82
3.3 Tyre size: Load rollers - Width		mm	60
3.5 Tyre size: rear wheels - Q.ty (X=driven)		nr	4
3.5 Tyre size: front wheels - Q.ty (X=driven)		nr	2
3.5 Rear balancing axle			No
3.6 Tread, front	b10	mm	155
3.7 Tread, rear	b11	mm	375

Dimensions

4.4 Lift height	h3	mm	115
4.9 Height of tiller in drive position max	h14	mm	1185
4.9 Height of tiller in drive position min	h14	mm	710
4.15 Height, lowered	h13	mm	90
4.19 Overall length	l1	mm	1596
4.20 Length to face of forks	l2	mm	411
4.21 Overall width	b1	mm	555
4.22 Fork dimensions - Thickness	s	mm	60
4.22 Fork dimensions - Width	e	mm	180
4.22 Fork dimensions - Length	l	mm	1185
4.25 Distance between fork arms	b5	mm	555
4.32 Ground clearance, centre of wheelbase	m2	mm	30
4.34 Aisle width	Ast	mm	2085
4.35 Turning radius	Wa	mm	1426

Performance data

5.2 Lifting speed laden	strokes	12
5.2 Lifting speed unladen	strokes	12
5.3 Lowering speed laden	m/s	0,06
5.3 Lowering speed unladen	m/s	0,02

Scale

Type	DFW 06 XPCA	
Digits	Q.ty	6
Digit height	mm	25
Kilograms		Yes
Lbs		Yes
Tare		Yes
Auto-off		Yes
Totalization		Yes
Counting		Yes
Operating time	h	50
Accuracy	%	0.05
Shear-beam load cells	Q.ty	4
Division	Kg	0.5
6.4 Battery voltage	V	6
6.4 Battery capacity	Ah	4

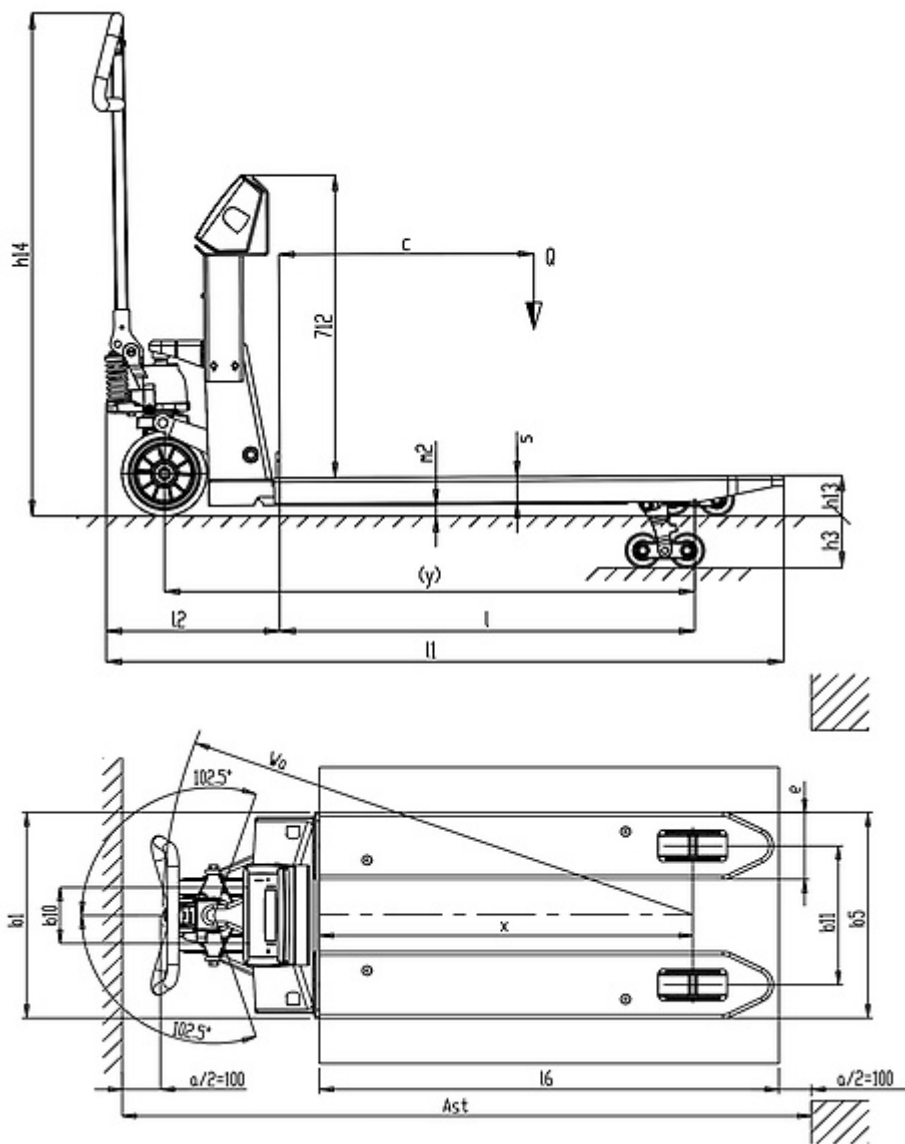

The information is aligned with the Data file at the time of download. Printed on 30/12/2020 (ID 587)

©2020 | PR INDUSTRIAL s.r.l. | All rights reserved | Image shown may not reflect actual package. Specifications subject to change without notice

